

DONALD A. GLASER

## Elementary particles and bubble chambers

*Nobel Lecture, December 12, 1960*

It is a very great honor and privilege that I have this opportunity to describe to you the invention, development, and uses of bubble chambers for studying elementary particles.

From the earliest beginning of serious scientific thought up to the present day, men have tried to understand the properties of matter by imagining it to be built up out of a small number of basic irreducible elements. According to current scientific ideas, these irreducible elements are actually sub-microscopic particles which are supposed to be indivisible and therefore not made up out of yet smaller particles. We imagine all matter to be agglomerations of molecules built up from atoms which are, in turn, constructed from electrons, protons, and neutrons. These three particles have definite masses, spins, electric charges, magnetic moments, and other properties. All electrons are supposed to be identical and so are all protons and all neutrons. During the last twenty years a number of other apparently indivisible particles have been discovered so that now there are thirty of them altogether. Although a few of these thirty have not yet been observed experimentally, they are included in the list because the theoretical expectation of their existence is very strong and it seems virtually certain that they will be observed during the next few years. Some of the thirty elementary particles were found experimentally, only after theoretical arguments had predicted their existence and the conditions required for creating and observing them. Others were discovered more or less accidentally before we had any theoretical ideas about them or their properties. Among these are the  $\mu$ -meson and the first « strange particles ». Although we have a lot of experimental knowledge about them there is still no satisfactory mathematical theory which can predict their physical properties or interpret their existence in terms of the other known elementary particles. Physicists find it distasteful to believe that all thirty of these elementary particles are « really fundamental », and hope some day to understand them all as compounds of a smaller number of truly fundamental particles or in terms of some other concepts involving simple underlying laws.

Advances in our knowledge of the elementary particles have depended heavily on the development of techniques for detecting them and observing their properties in detail. Among the most important instruments used in these experimental studies have been the cloud chambers and the nuclear emulsion. Both techniques permit detailed visual study of the paths of charged elementary particles, but each has limitations that seriously hamper some studies of elementary particles and other phenomena of high-energy nuclear physics.

I became interested in trying to devise new experimental methods for investigating the physics of elementary particles in 1950, not long after the new « strange particles » had been discovered in cosmic rays. In those days a rather small number of these particles had been observed, and they were still called « V-particles » or « pothooks » because of their unusual appearance in the cloud chamber photographs. In fact, I remember that when I left the California Institute of Technology in 1949 after finishing my doctoral research on cosmic radiation under the direction of Professor Carl D. Anderson, there was written at the top of his blackboard the question: « What have we done about the pothooks today? » No one had predicted the existence of these particles or had any idea how they might fit into theoretical schemes describing the particles already well known at that time. Their discovery in cosmic ray interactions in 1947 by Butler and Rochester and later observation by others created high excitement among physicists. Here was a whole new family of particles that might well lead to some novel and deep ideas about the laws and symmetries of Nature on the submicroscopic level of the elementary particles. More experimental information was desperately needed concerning the production, decay, and interactions of these new particles.

Greatly stimulated by these developments, I began to wonder whether it would be possible somehow to speed up the rate of observing the strange particles and their interactions. Most examples of their decays were seen in cloud chamber photographs of penetrating cosmic ray showers originating in lead plates just above the chamber. Because of the rarity of strange-particle production and the low density of gas in a cloud chamber, production events almost never occurred in the gas itself. For this reason it was difficult to get convincing experimental evidence on even such simple ideas as the law of associated production, which had been invented to explain how the new particles could have such long lifetimes. Nuclear emulsions are not useful in these studies because the neutral « V particles » have typical mean decay

lengths of a few centimeters. This makes it virtually impossible to associate correctly a decaying  $\Lambda^{\circ}$  or  $K^{\circ}$  with its parent star in an emulsion stack containing a reasonable density of events.

There was therefore a great need for a particle detector of high density and large volume - tens to hundreds of liters - in which tracks could be photographed and scanned at a glance, and in which precision measurements of track geometry could be made. Expansion cloud chambers which operated with internal gas pressures up to 300 atmospheres had been built for this reason, but they were elaborate and cumbersome machines which required waiting times of 15 to 30 minutes between expansion cycles.

Since all detectors capable of recording the passage of a single minimum ionizing particle must use some amplifying process to be sensitive to the minute amounts of energy deposited by a fast charged particle, I began to list all the amplifying mechanisms I could imagine that might serve as the basis for a detector of the type that was needed. Previous detectors had used the instability of a gas, liquid, or solid, against dielectric breakdown in an intense electric field, the chemical instability of nuclear emulsion with respect to its developing solution, or the thermodynamic instability of a supercooled or supersaturated vapor. Since I wished to attain high density without using very high pressures, I considered mainly instabilities that can exist in liquids and solids, such as chemical instabilities including the tendency of monomers to polymerize, instabilities due to intense electric fields, and thermodynamic instabilities such as are present in supercooled liquids, superheated solids, or superheated liquids. At the time that I was studying these instabilities, I knew that the large proton synchrotrons in the few GeV energy range would come into operation in the early 1950's and that they would have pulse repetition times of a few seconds. It was therefore important that the new detector be able to cycle in a few seconds to be most useful with these machines as well as with the cosmic rays. For this reason I rejected chemical and solid systems as being probably too difficult to recycle rapidly.

The thermodynamic instability of a superheated liquid can be used to detect minimum ionizing radiation only if the density of ionization energy deposited in the liquid along the path of the particle is sufficient to form a vapor bubble nucleus large enough to grow to photographable size. If the vapor pressure in a bubble at the temperature  $T$  exceeds the external pressure applied to the liquid by the amount  $\Delta P$ , the radius of this critical nucleus is

$$r_c = \frac{2\sigma(T)}{\Delta P}$$

where  $\sigma(T)$  is the surface tension of the liquid-vapor interface. A lower limit for the nucleation energy required for forming this bubble is obtained by calculating the energy required for its isothermal reversible formation

$$W = \frac{16\pi\sigma^3(T)}{3(\Delta P)^2}$$

Then the minimum energy density required per unit length of track is

$$\frac{W}{2r_c} = \frac{4\pi\sigma^2(T)}{3AP}$$

If we imagine that we can quickly reduce the external pressure on the hot liquid almost to zero compared with the vapor pressure as a means of preparing the final superheated state, we approximate  $\Delta P$  by  $P(T)$ , the saturated vapor pressure. Then the energy loss of the minimum ionizing particle must exceed

$$\frac{W}{2r_c} \simeq \frac{4\pi\sigma^2(T)}{3P(T)}$$

When we insert the actual value of the energy loss of a minimum ionizing particle, we find that the only way to attain the low surface tension and high vapor pressure required by this equation is to raise the temperature of the liquid to the vicinity of its critical temperature, since the surface tension vanishes at the critical temperature. In fact, it turns out that the temperature must be about one-half to two-thirds of the way from the boiling point to the critical point for successful bubble chamber operation.

Closer estimates of the required degree of superheat can be made only by assuming specific mechanisms for conversion of ionization energy to bubble nucleation energy. We must first ask whether macroscopically measured values of  $\sigma(T)$  and  $P(T)$  apply for bubbles  $10^{-6}$  cm in diameter. In the theory of cloud chamber operation, it is important that the equilibrium vapor pressure at a convex liquid surface is much larger than at a flat surface. Is there a similar effect at concave surfaces? It was several weeks before I

could answer this question, because each thermodynamic argument I used led to the conclusion that the vapor pressure inside a vapor bubble is the same as that at a flat interface, though I found that nearly all of the thermodynamics textbooks disagreed with me. Finally I found a discussion of this question, which had apparently been a subject of a serious dispute as late as 1939, in an excellent book, *Kinetik der Phasenbildung*, by M. Volmer, in which my conclusions were supported.

Little experimental information on the surface tension of highly concave surfaces was available, but it seemed plausible that there should not be a large dependence on curvature when the radius of curvature is very much larger than the average intermolecular distance in the liquid.

Two detailed mechanisms for bubble formation suggested themselves. In one, it was supposed that clusters of ions of like sign are produced occasionally along the track, and form bubbles by mutual electrostatic repulsion. In the second, it was supposed that excited atoms and molecules formed directly by the primary particle and by ion recombination converted their excitation energy into local heating of the liquid through superelastic collisions of the second kind. Both models made bubble formation along the tracks of minimum ionizing particles appear to be a very difficult and implausible process. I was encouraged by the idea that even if the primary ionization energy was insufficient, secondary delta rays with even a few hundred volts of energy or more would form frequently along the track and deposit their energy densely in a small volume as they stopped in the liquid. Coulomb scattering would tend to curl up the stopping electron tracks and increase the volume density of their energy deposit.

For a first experimental test of these ideas, I chose diethyl ether because of its relatively low surface tension, critical temperature, and critical pressure, and because it was cheap and easy to obtain in pure form. One particular calculation using the electrostatic model predicted that diethyl ether would be nucleated to boil by ionizing radiation at about 140°C at one atmosphere although its boiling point is only 34.6°C. It seemed to me unreasonable that such an enormous degree of superheat should be attainable experimentally, so I looked in the literature of the physical chemists to see what was known about the maximum attainable superheats. Finally I found a remarkable paper\* describing attempts to superheat diethyl ether, a liquid which these authors had apparently chosen for the same reasons of convenience that dictated my choice. Imagine my excitement when I read that they had been

\* F. B. Kenrick, C. S. Gilbert, and K. L. Wismer, *J. Phys. Chem.*, 28 (1924) 1927.

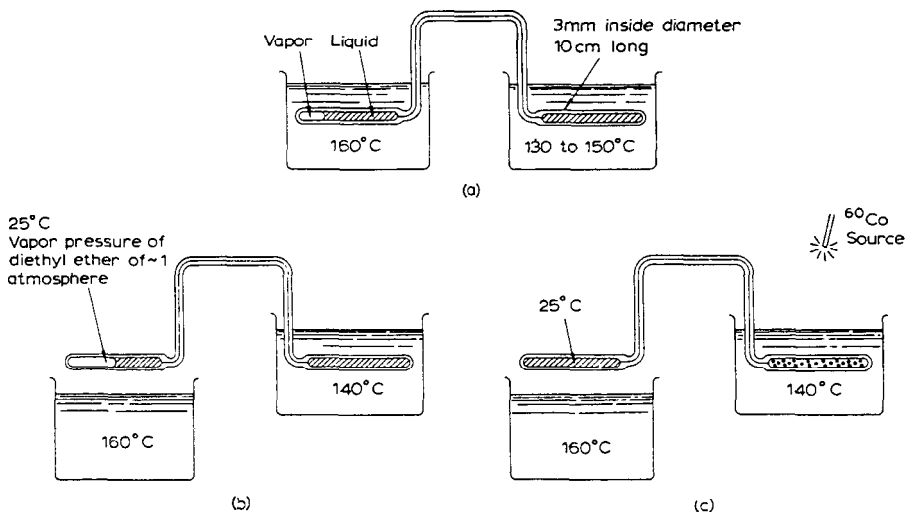

Fig. 1. Diagram of experiment demonstrating that superheated diethyl ether can be made to boil by ionizing radiation.

(a) Pressure on enclosed diethyl ether is high due to vapor pressure of the liquid at 160°C. Temperatures shown are maintained by hot oil baths; (b) 160°C bath removed. Temperature drops quickly in a few seconds to 25°C. Pressure on total system about 1 atmosphere. Diethyl ether in the bulb at 140°C is now highly superheated; (c) Boiling is triggered in the superheated diethyl ether by radiation from a  $^{60}\text{Co}$  source.

able to maintain diethyl ether superheated for hours at 130°C and one atmosphere, but that at 14°C the liquid erupted at erratic time intervals after being brought rapidly to the high temperature. To demonstrate the « capriciousness » of this phenomenon, they quote a typical series of 30 consecutive « waiting times ». When I examined these times, I found them to be consistent with a Poisson distribution corresponding to the random occurrence of a nucleating event which disrupted their small volume of liquid with an average waiting time of about 60 seconds. From the reported geometry of the superheating apparatus, I estimated that its total « counting rate » for ionizing events in the liquid due to cosmic rays plus radioactive background at sea level was also about one count every 60 seconds!

To make a simple test of the hoped-for triggering of superheated diethyl ether by ionizing events, I did the experiment diagrammed in Fig. 1. A heavy-walled capillary tube of the shape shown was evacuated and filled with pure diethyl ether vapor and liquid. When the pressure on the liquid is reduced by cooling the bulb containing some vapor, the pressure drops

to about 1 atmosphere, superheating the liquid in the 140°C bulb. When exposed to gamma radiation from a  $^{60}\text{Co}$  source, this hot ether erupts into violent boiling, instantly as far as the eye can tell.

It should be remarked parenthetically that before making these detailed calculations and experiments, I wanted to be sure not to overlook simple experimental possibilities, so I took some bottles of beer, ginger ale, and soda water into my laboratory, warmed them as much as I dared, and opened them with and without a radioactive source nearby. There was no apparent gross difference in the way they foamed. Water, of course, turns out to be just the wrong substance to use in a bubble chamber because it has a large surface tension and a high critical pressure.

Now that there was experimental proof of the reality of this new physical phenomenon on which a bubble chamber technology could be based, it was important to find out if minimum ionizing particles could initiate boiling and if the bubbles formed accurately along the path of the particle. Unless

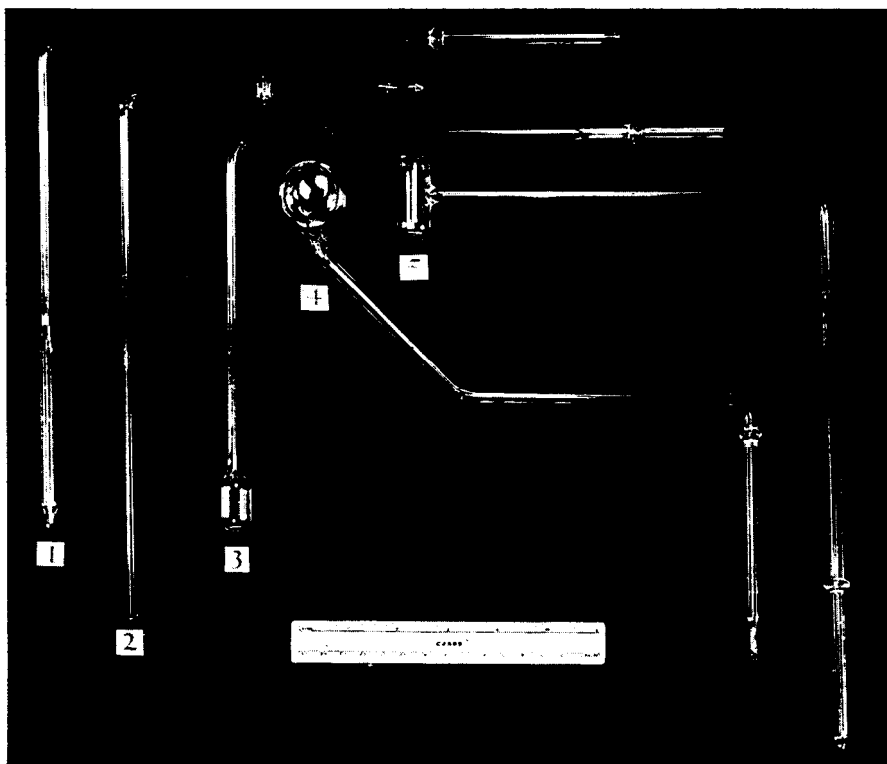

Fig. 2. Some of the first Pyrex-glass bubble chambers.

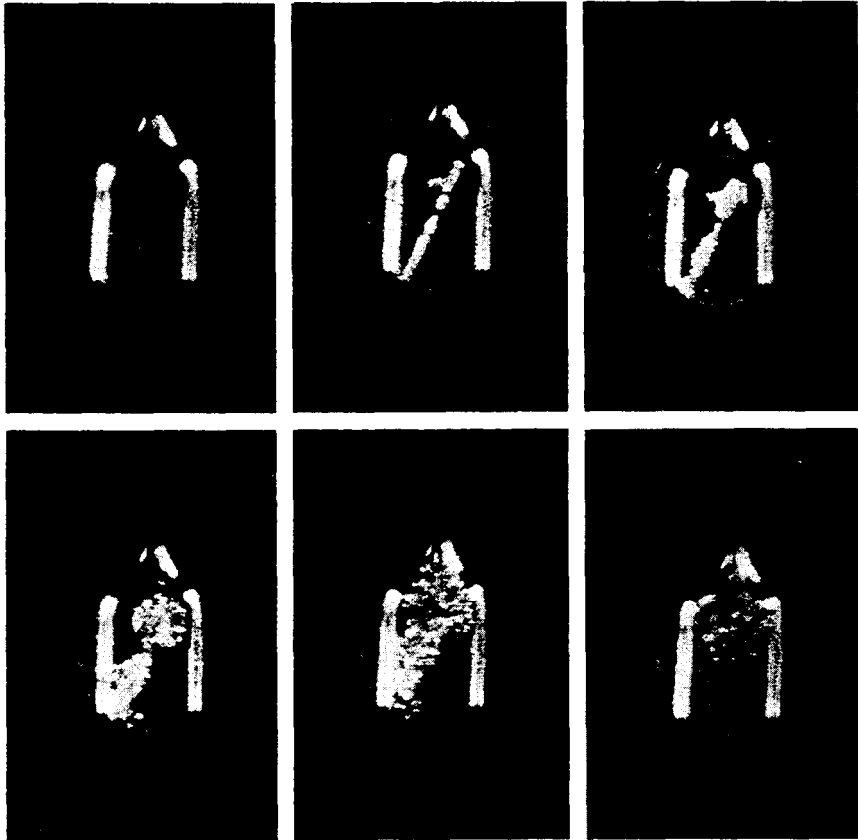

Fig. 3. High-speed movies taken at 3,000 pictures per second of eruptive boiling initiated in diethyl ether at  $135^{\circ}\text{C}$  by a penetrating particle. The pictures shown were taken at 0,  $\frac{1}{3}$ , 4, 22, 71, and 250 milliseconds. The fast two are consecutive pictures. The chamber is about 1 cm inside diameter.

the bubble chamber could make accurate tracks of minimum ionizing particles, it would be of little use in high-energy physics experiments.

To look for tracks, I made a number of small Pyrex-glass bubble chambers containing a few  $\text{cm}^3$  each of diethyl ether. Some of them are shown in Fig. 2. A bath of hot oil maintained the required temperature, and a piston operated by a hand crank controlled the pressure. Each time the pressure was reduced by a quick turn of the hand crank, a high-speed movie camera recorded the onset of boiling after the usual few seconds of waning time when the ether was in a quiescent superheated state. Sometimes the boiling



started along a well defined track as shown in Fig. 3, which is taken using chamber 3 in Fig.2. From these movies taken at 3,000 pictures/second, one sees that the bubbles grow to be more than a millimeter in diameter in 300 microseconds. Finer tracks were obtained by constructing an automatic device for expanding and recompressing the chamber every 10 seconds. Photographs of the chamber were taken with a xenon flashlamp whenever a vertical Geiger counter telescope indicated the passage of a penetrating cosmic ray particle during the few seconds of sensitive time following each expansion. These photographs, shown in Figs. 4 (a, b, c) proved that bubble chambers could yield precision measurements of events involving minimum ionizing tracks.

Although this series of experiments established with certainty that bubble chambers were feasible and had the right characteristics for elementary-particle studies, engineering development was needed before large chambers for serious experiments could be built. There were two main questions. What

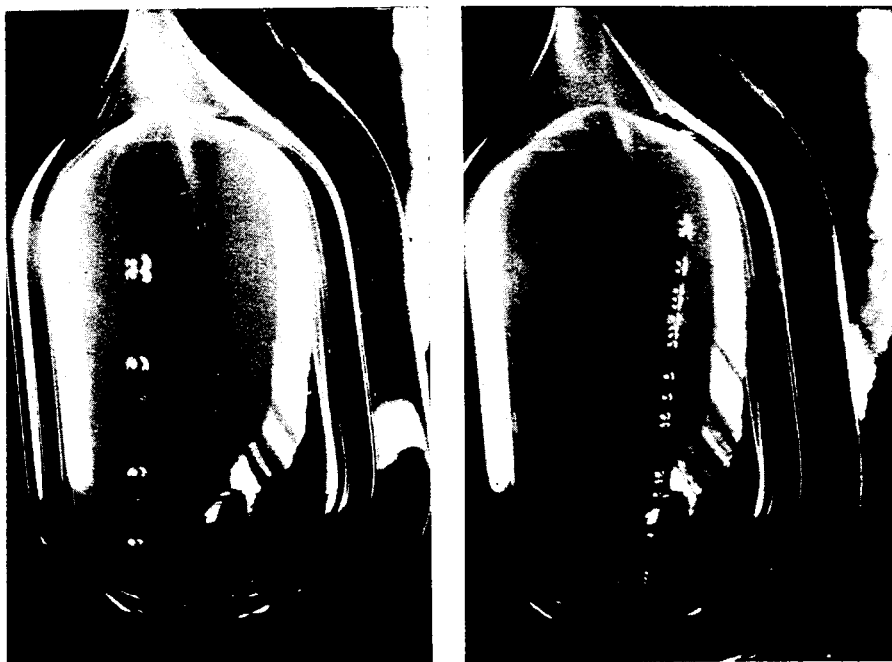

Fig. 4 (a,b). Penetrating cosmic ray tracks in 3 cm<sup>3</sup> diethyl-ether bubble chamber. (Random expansion and counter-controlled flashlamps.)  
(a) 60 microsecond flash duration, 139°C; (b) 10 microsecond flash delay, 20 microsecond flash duration, 140°C. (Fig. 4 (c) on next page.)



Fig. 4 (c). Penetrating cosmic ray tracks in 3 cm<sup>3</sup> diethyl-ether bubble chamber. (Random expansion and counter-controlled flashlamps.)  
(c) 10 microsecond flash delay, 5 microsecond flash duration, 141°C. The track in (c) is deflected about 2° in the middle of the chamber.

other liquids could be used in bubble chambers? How could chambers with hundreds of liters of sensitive volume be constructed? Many laboratories the world over pursued this development with great vigor and ingenuity.

Diethyl ether had been used in the first experiments for reasons of experimental convenience. Liquid hydrogen was obviously the physicists' dream as a working liquid because the interpretation of events in hydrogen are so straightforward. Using the electrostatic theory of bubble chamber operation, I estimated that hydrogen would work at about 27°K. Although I now have excellent reasons for believing the thermal or « hot track » theory of bubble nucleation is correct rather than the original electrostatic mechanism, the two theories give nearly the same scaling law for relating the operation conditions of different liquids. Therefore, the basically wrong electric theory gave correctly the operating temperatures for hydrogen, deuterium, helium, freon, propane, xenon, and a host of other liquids. At the University of Michigan there were no cryogenic facilities in 1953, so I trav-

elled to the University of Chicago and worked on liquid-hydrogen bubble chambers with Hildebrand and Nagle, who soon showed that superheated liquid hydrogen was radiation sensitive. Shortly after that, Wood at Berkeley photographed the first tracks in liquid hydrogen. Many other liquids were tested in our laboratory and in other places. No liquid that has been tested seriously has failed to work as a bubble chamber liquid. The choice of liquids depends only on the physical objectives of the experiment and on engineering and economic considerations.

It did not seem practical to make large chambers out of a single piece of pyrex glass. We therefore fabricated a small chamber with an aluminum body and flat glass windows sealed with rubber gaskets. Certainly there was no hope of maintaining a liquid superheated for any length of time in such a chamber because boiling begins easily at gaskets and scratches in the metal. We hoped that we could expand the chamber fast enough to keep the pressure in the interior of the chamber low for at least a few milliseconds, even though boiling begins instantly at the walls. Fig. 5 shows the 5-cm chamber used to test this method. Figs. 6 (*a, b, c, d, e*) shows a sequence of snapshots taken at various times after the beginning of the expansion. These pictures proved that a chamber fabricated of ordinary materials could have a sensitive time of a few milliseconds, long enough for use with large particle accelerators. Wood proved the same thing independently with his first small hydrogen chamber a short time before we did. These experiments made possible the design and construction of really large chambers containing hundreds of liters of liquid.

In Fig. 7 is shown a 15-cm propane chamber we exposed to the Brookhaven Cosmotron - the first bubble chamber to be used for experiments in high-energy physics. In Figs. 8, 9, 10, and 11 are shown our 30-cm propane chamber, 30-cm /21-liter/ xenon chamber, the xenon chamber fully assembled for an experiment, and finally the largest chamber operating now in the world, Alvarez's 180-cm /500-liter/ hydrogen chamber. Other really large chambers are in use or under construction at Brookhaven, Chicago, Geneva, Dubna, Saclay, London, and other high-energy physics centers. Smaller chambers in large numbers and great varieties are in use all over the world.

Large quantities of data on elementary particles and their interactions are being produced by these chambers. A number of new particles and phenomena have been discovered by their use. Precise information on masses, spins, lifetimes, parity violating decays, branching ratios, and polarizations has

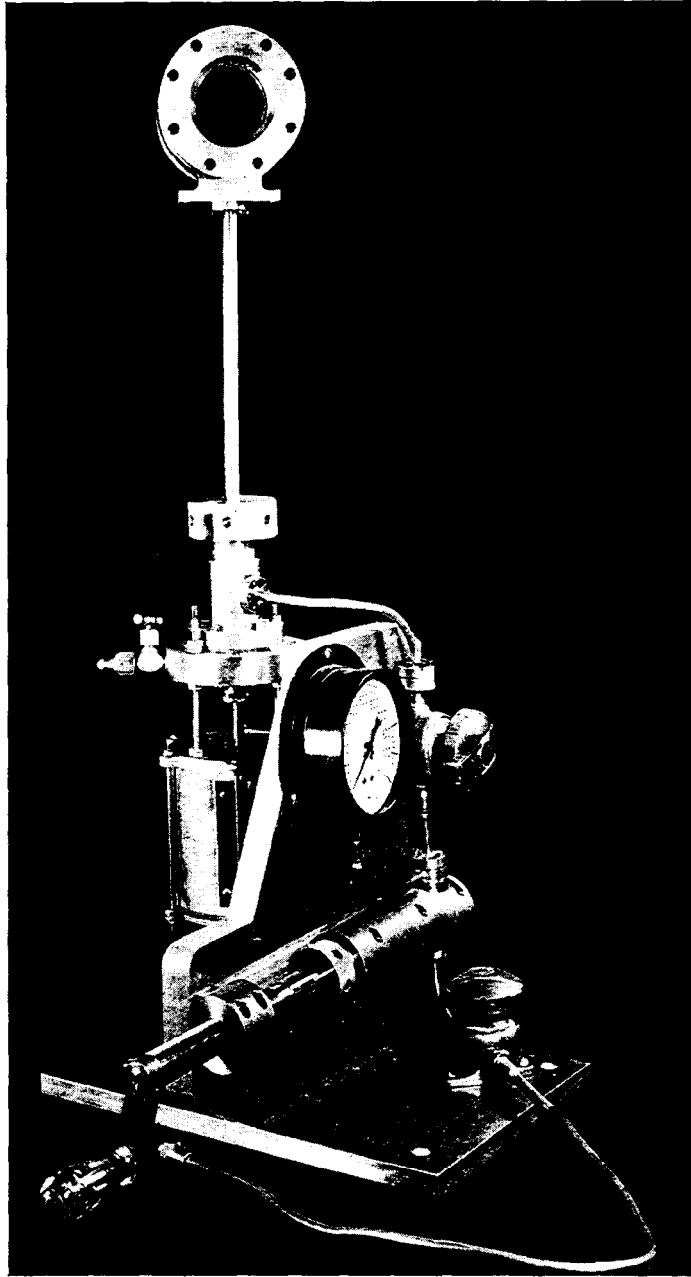

Fig. 5. An aluminum bubble chamber 5 cm in diameter with its expansion mechanism and volume adjustment system for testing the principle of the «dirty» bubble chamber.

been obtained for these particles. Nuclear fusion catalyzed by  $\mu$ -mesons was discovered in a hydrogen bubble chamber. Figs. 12 through 14 are pictures showing some of the elementary-particle phenomena being studied now with these chambers.

Because of the high density and rapid cycling rate of bubble chambers, we now have abundant information on particle production, interaction, and decay as observed with beams at the large accelerators. It was a disappointment to discover that bubble chambers are not easy to use for cosmic ray experiments since they cannot be operated using counter-controlled expansions as can cloud chambers. We have established experimentally that the lifetime of the « latent bubble-track image » produced by a charged particle is less than  $10^{-4}$  seconds and our theoretical estimates indicate that it may actually be about  $10^{-8}$  seconds. Since mechanical expansion of a bubble

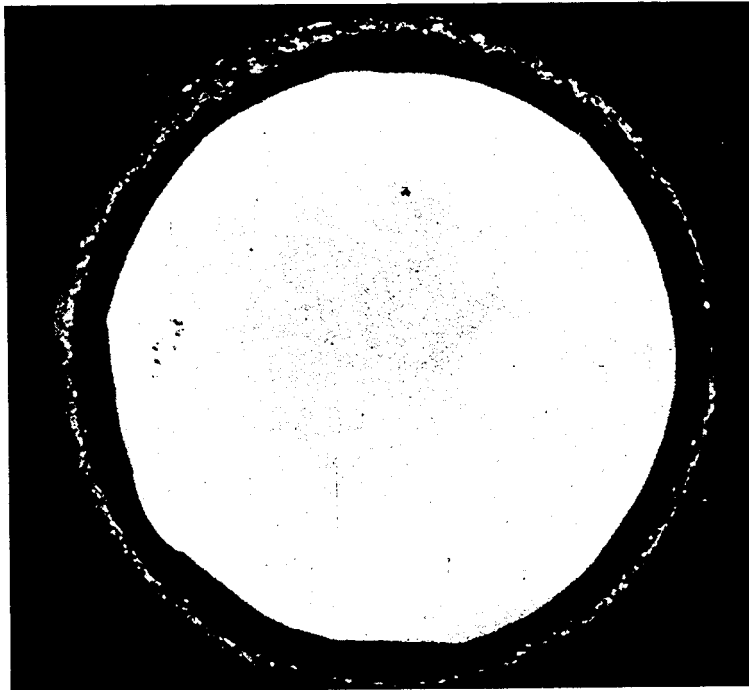

Fig. 6 (a). Operation of a « dirty » diethyl-ether chamber, 5 cm in diameter and 2.5 cm deep at  $154^{\circ}\text{C}$ . Photographs are taken with a 5 microsecond flash duration at different moments after the beginning of the expansion process; *11 milliseconds, no radiation*: violent boiling occurs at the gaskets but no bubbles have formed in the interior of the liquid or at the glass windows. (Figs. 6 (b, c, d, e) on the following pages.)

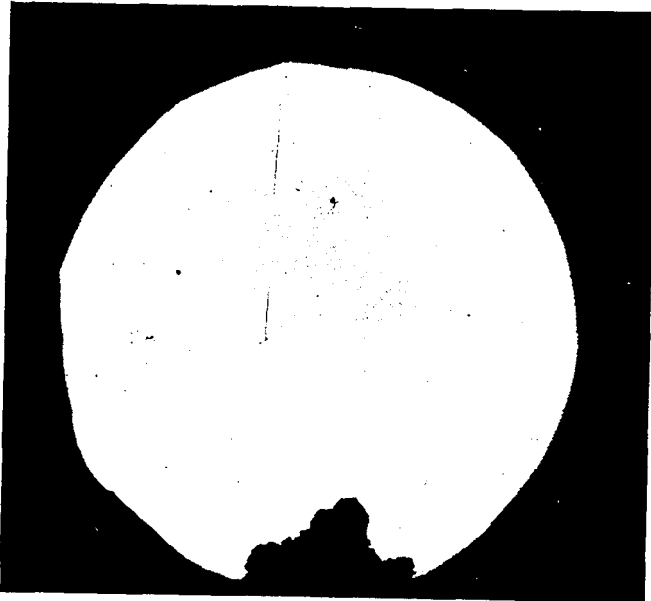

Fig. 6 (b). 12.5 milliseconds, no radiation: boiling has progressed further and a jet of vapor shoots out of the expansion orifice at the bottom of the chamber.

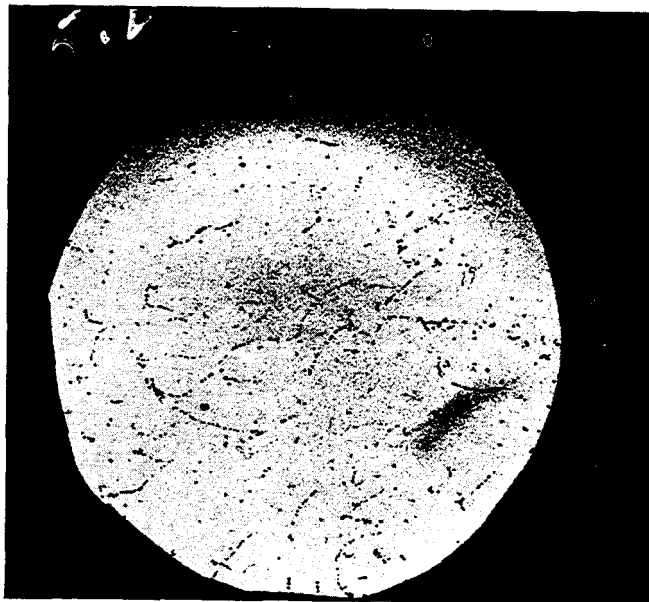

Fig. 6 (c). 5.4 milliseconds, radium source nearby: some fine and some larger tracks are visible, the finer ones showing normal bubble density indicating that the chamber is at full sensitivity.

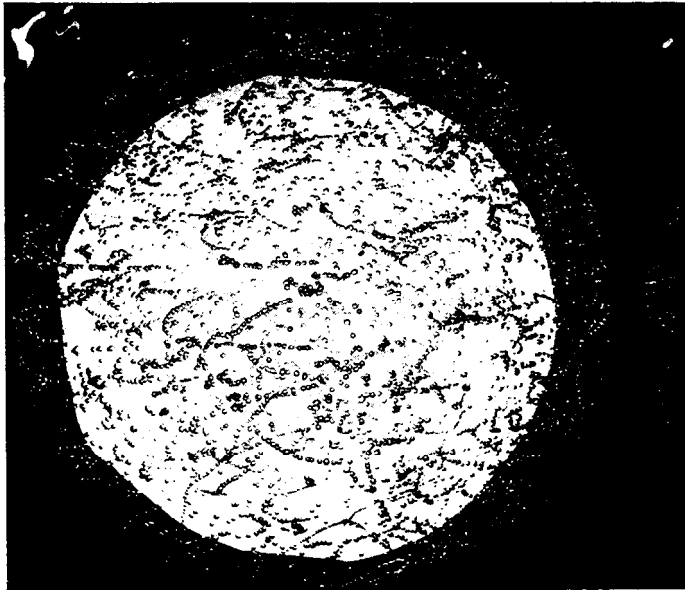

Fig. 6 (d). 7.55 milliseconds, radium source nearby: although the bubbles on the oldest tracks have grown quite large, new tracks are still being formed.

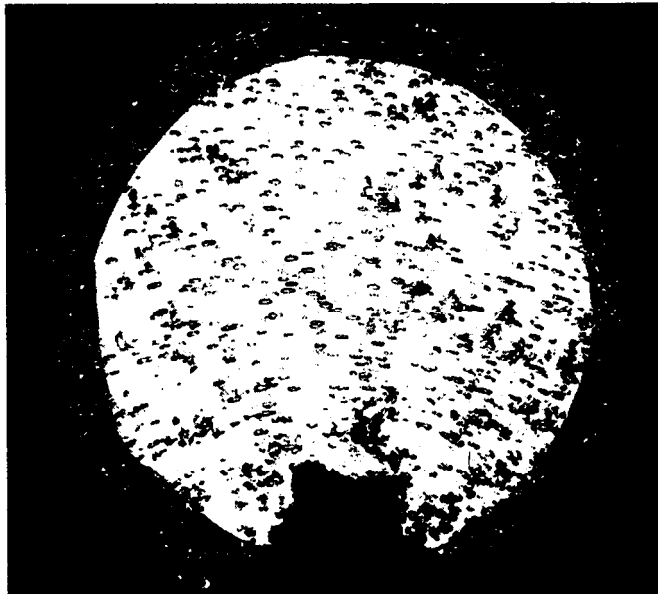

Fig. 6 (e). 12.5 milliseconds, weak radium source nearby: vapor jet from the expansion orifice causes a sudden pressure wave in the chamber. It distorts the tracks and ends the sensitive time abruptly.

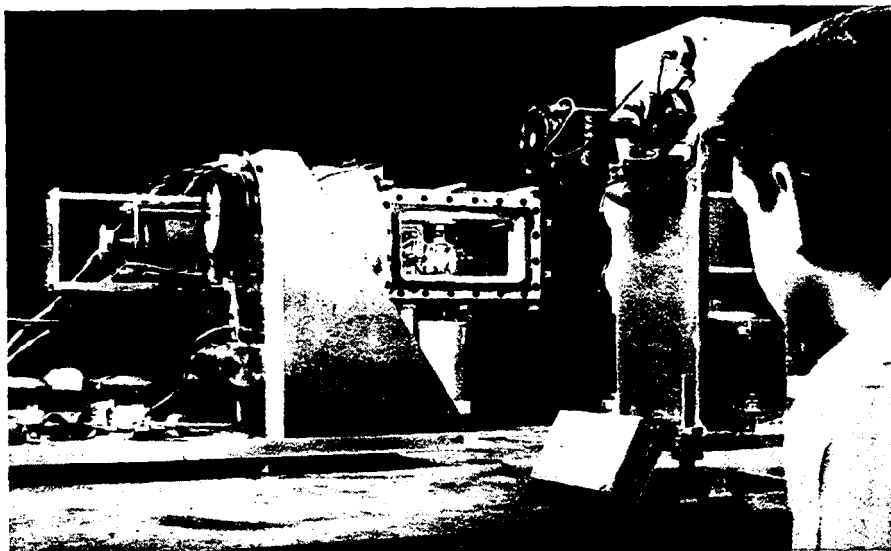

Fig. 7. A 15-cm propane bubble chamber showing stereoscopic camera, expansion system, and flashlamp. When in use, a small oven with windows fits around the chamber to maintain it at a temperature of  $55^{\circ}\text{C}$  to  $60^{\circ}\text{C}$ .

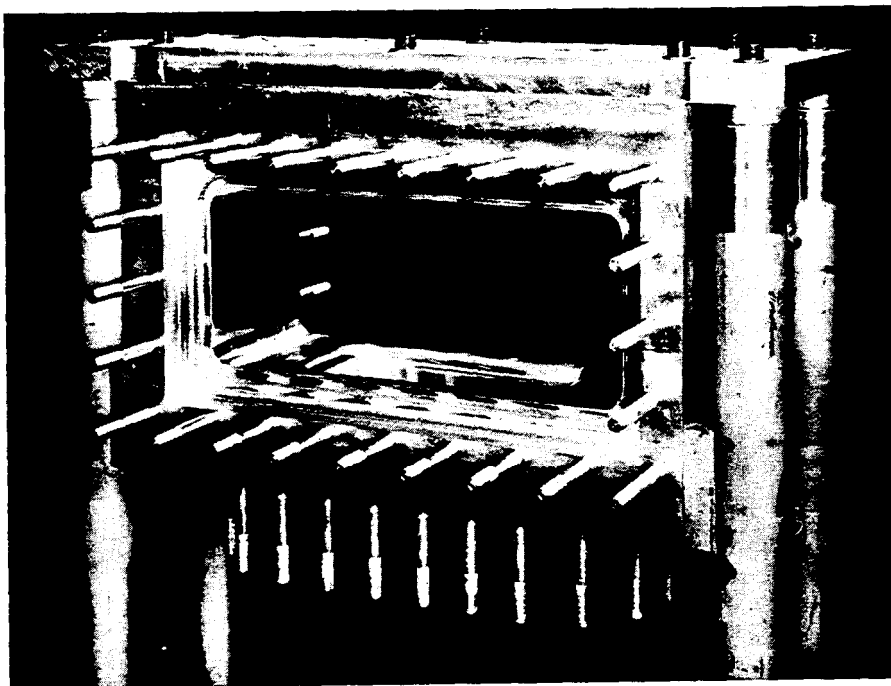

Fig. 8. The stripped aluminum body of a 30-cm propane bubble chamber.



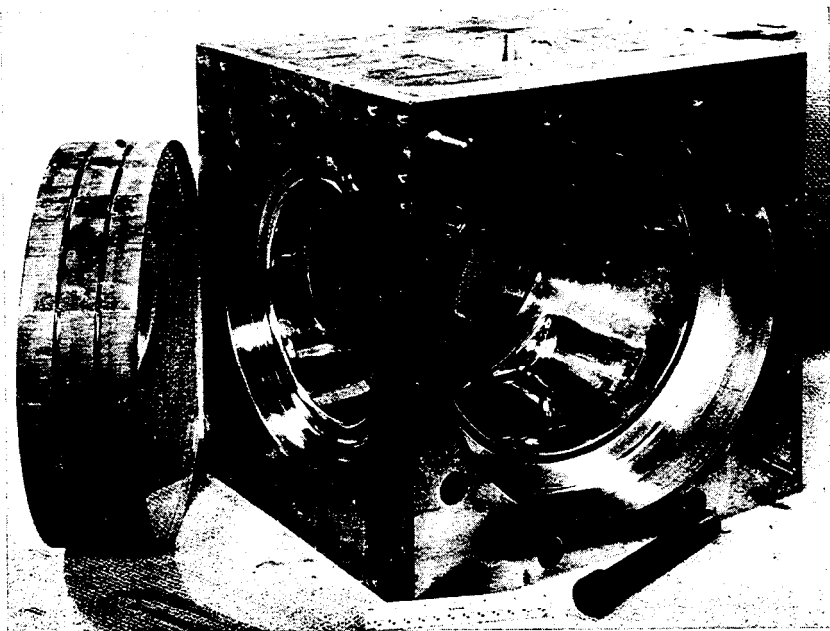

Fig. 9. The stripped aluminum body and test window for 21-liter, 30-cm xenon bubble chamber.

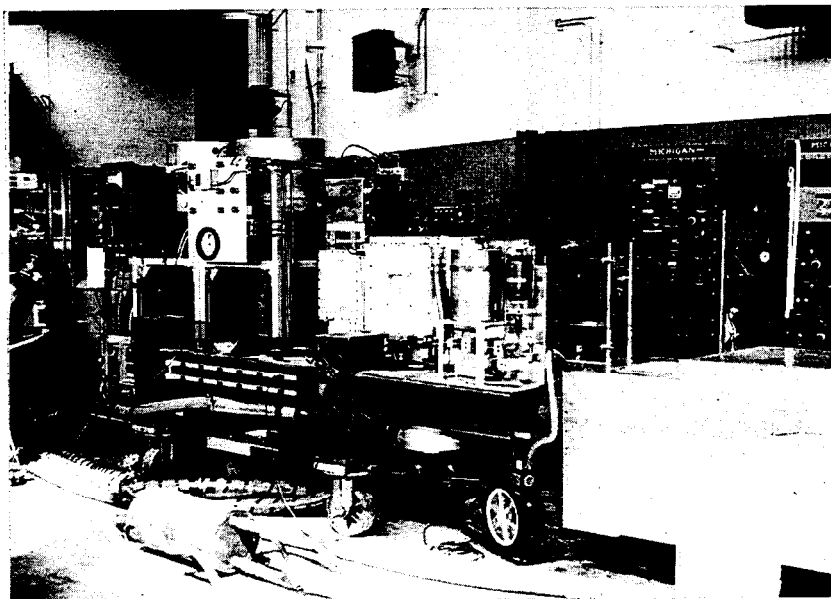

Fig. 10. Xenon bubble chamber assembled ready for use at the Bevatron, except for insulating refrigeration.

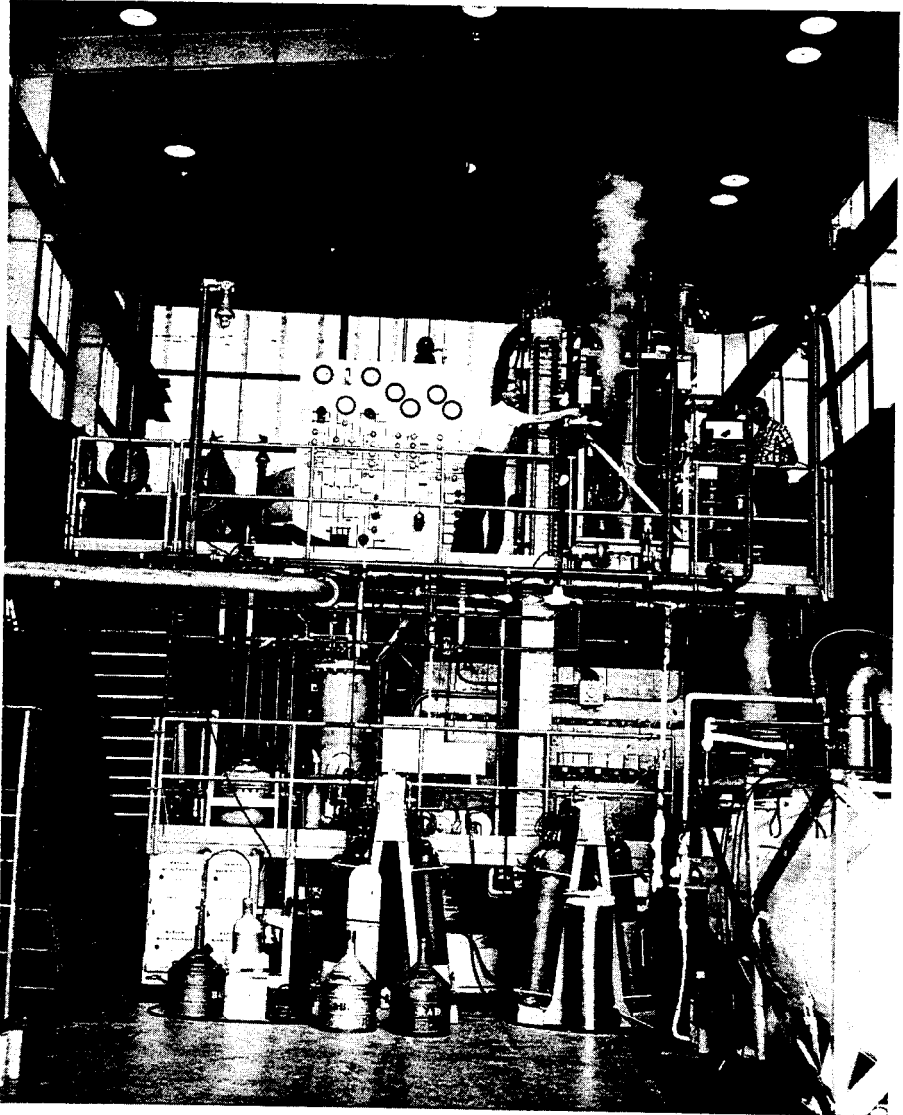

Fig. 11. Alvarez's 180-cm, 500-liter hydrogen bubble chamber assembled with magnet, ready for doing an experiment at Berkeley.

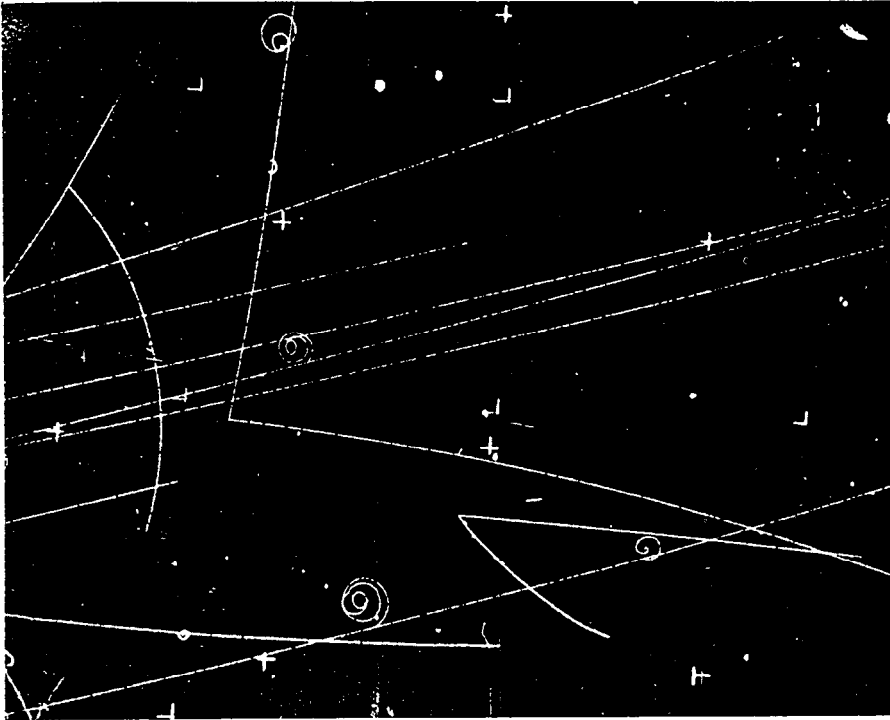

Fig. 12. Associated production,  $\pi^- + p \rightarrow \Lambda^0 + K^0$  at about 1 GeV with subsequent decays in Alvarez's hydrogen bubble chamber.

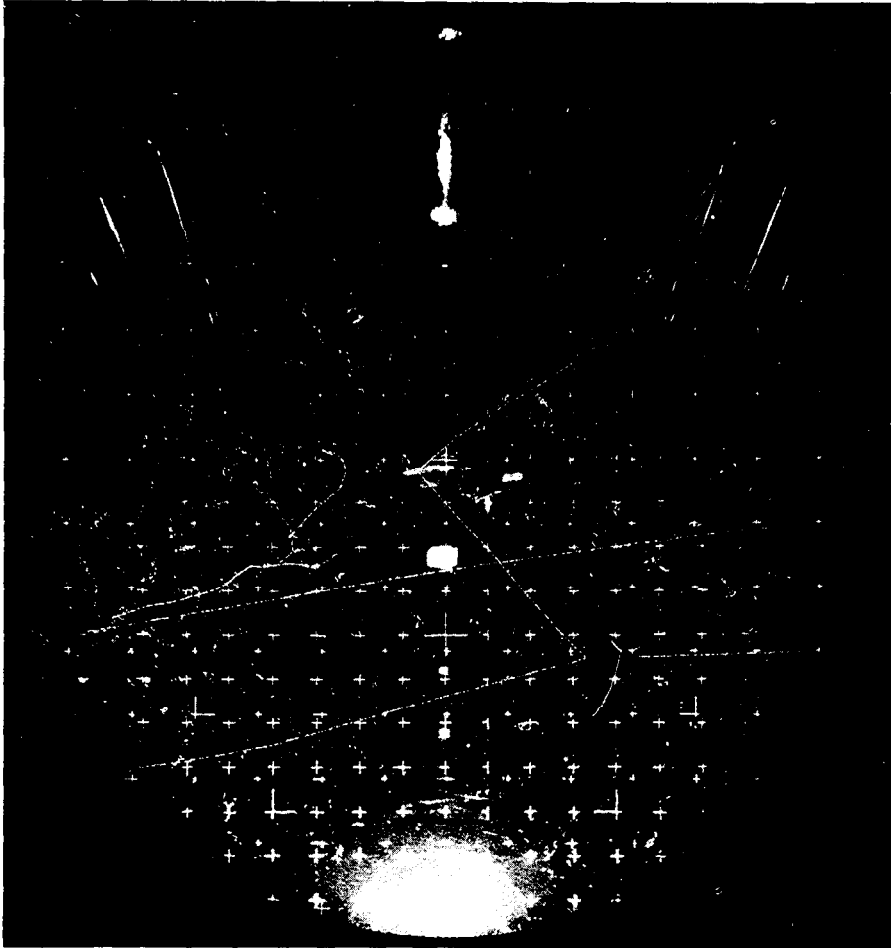

Fig. 13. Associated production,  $\pi^- + p \rightarrow \Lambda^0 + K^0$  at about 1 GeV seen in xenon bubble chamber with subsequent decays. The decay tracks of the  $\Lambda$  are very short because of the high density of the xenon.

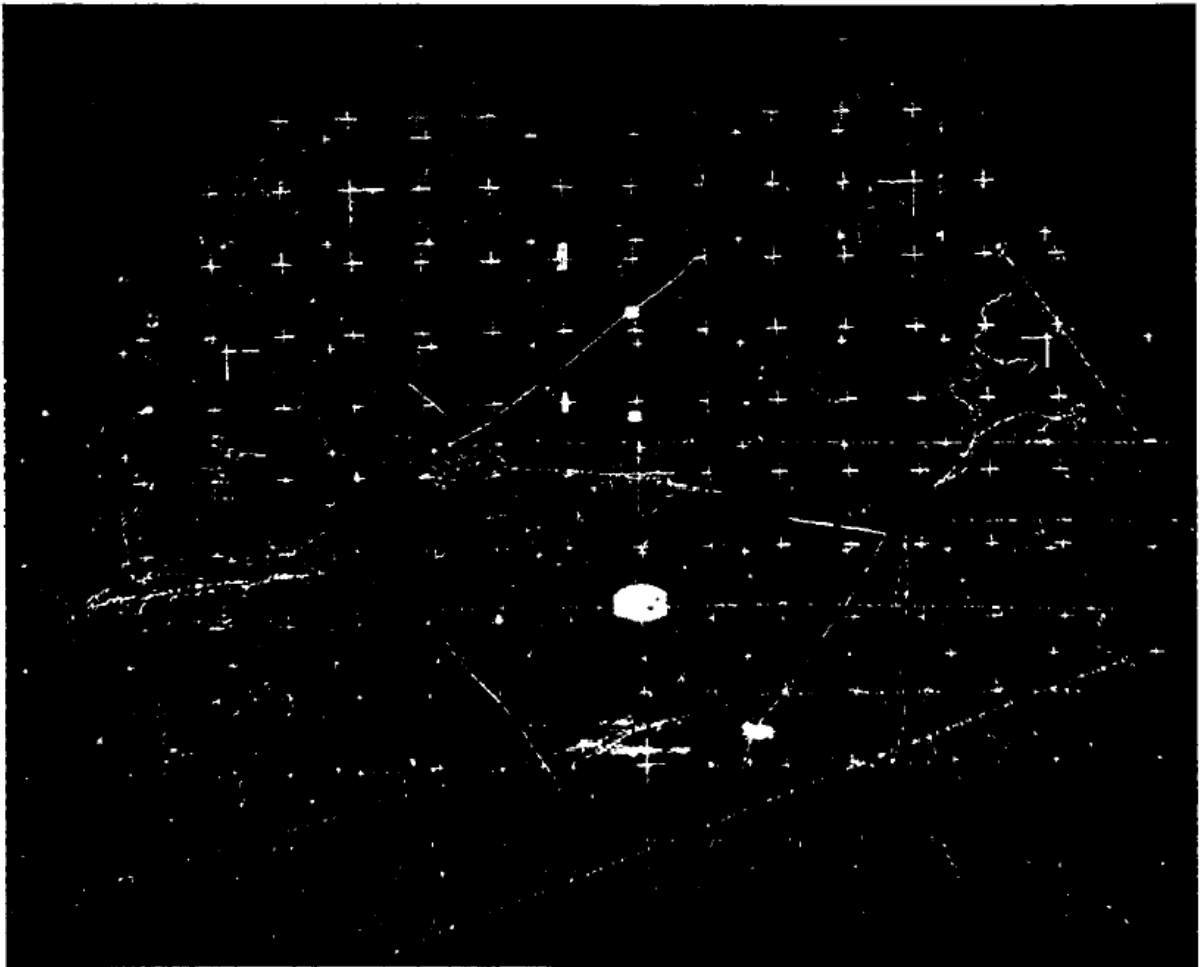

Fig. 14. The same process,  $\pi + p + \Lambda^0 + K^0$  at about 1 GeV followed by  $\Lambda^0 \rightarrow p + \pi^-$  and  $K^0 \rightarrow \pi^0 + \pi^0$  followed by  $\pi^0 \rightarrow 2\gamma$  in which all four gamma rays make electron showers. Complete processes like this involving gamma rays are efficiently detected in xenon because of its short radiation length.

chamber takes much longer than this, it is impossible to make expansions only when interesting events are detected by counter arrays because the bubble nuclei will have disappeared by the time the chamber has become sensitive. By random cycling and various ways of extending the length of the sensitive time, it may be possible to maintain a bubble chamber in the sensitive condition for 10% of the time. Beams of artificially produced particles can be timed to arrive at a bubble chamber just when it reaches full sensitivity. For use with particle accelerators the bubble chamber is ideal because it can be made to be sensitive only during the short time of beam arrival. General background ionization does not then complicate the pictures very much.

In its various forms the bubble chamber has solved many of the problems of obtaining large amounts of precise pictorial information on processes involving energetic elementary particles. At the same time it has created a new problem by providing each active laboratory with millions of photographs each year. These photographs require careful, intelligent inspection and measurement with coordinate accuracies of the order of 1 micron on the film. Measuring projection microscopes to do the last step have been constructed to be able to follow interesting tracks semi-automatically and punch the coordinate information onto cards which are later fed into high-speed digital electronic computers. From these computers come geometric, kinematic, and dynamical conclusions which identify known particles, measure energies, and identify known processes. Now we are faced with the problem of finding and measuring these events as fast as the bubble chamber and accelerator can produce them. Although we can contemplate staffs of 50 specialists engaged in this work at a single laboratory, or for a single large bubble chamber, a staff of 500 or 5,000 people seems impossible. Yet we can ask important questions in basic physics which would be answered if we had such a huge staff studying photographs. As a result, many bubble chamber physicists have turned their attention toward developing automatic pattern recognition, measuring, and computing machines. Some day it is dreamed that such a machine, armed with a memory filled with full knowledge of all known processes occurring in high-energy physics, will devour miles of film each day, duly noting the numbers, characteristics, and types of all the known processes it recognizes. Only when it cannot « understand » an event by searching its memory, will it ring a bell to call over a physicist who will try to understand the new process. A start has been made in this direction and in three to five years we expect to use the first machines capable of

recognizing and interpreting a large class of known events. Armed with such formidable experimental means, the limitations of our imagination (and our ability to keep all these monstrous machines in operation) define the limits of the questions we may hope to answer about the experimental behavior of the elementary particles.

Since this lecture is intended to be a personal and historical description of research rather than a complete review article, the reader is referred to the following review sources for further and more detailed information.

D. A. Glaser, « The Bubble Chamber », *Handbuch der Physik*, S. Flügge (Ed.), Springer-Verlag, Berlin, 1958, Vol. 45, p. 314.

H. Slätis, « Survey Article on Bubble Chambers », *Nucl. Instr. Methods*, 5 (1959) 1.

D. V. Bugg, « The Bubble Chamber », *Progress in Nuclear Physics*, O. R. Frisch (Ed.), Pergamon Press, London, 1959, Vol. 7. p. 1.